

Capillary Microfiltration Module

HYDRAcap® MAX 80

Performance[†]	Filtrate Flow: Filtrate Turbidity: Bacteria removal:	15.7 – 51.0 gpm (3.6 – 11.6 m ³ /h) ≤ 0.10 NTU ≥ 4 log
Type	Configuration: Membrane Polymer: Nominal Membrane Area: Fiber Dimensions: Pore size:	Capillary Microfiltration Module PVDF 1130 ft ² (105 m ²) ID 0.024" (0.6 mm), OD 0.047" (1.2 mm) 0.1 micron
Application Data[‡]	Typical Filtrate Flux Range: Maximum Applied Feed Pressure: Maximum Transmembrane Pressure: Instantaneous Chlorine Tolerance: Maximum Chlorine Exposure: Maximum Instantaneous Feed Turbidity: Maximum Operating Temperature: pH Operating Range: Cleaning pH Range: Operating Mode:	20 – 65 gfd (34 – 110 l/m ² /h) 73 psig (5.0 bar) 30 psig (2.0 bar) 5000 ppm 750,000 ppm-hrs 300 NTU 104 °F (40 °C) 4.0 – 10.0 1.0 – 13.0 Outside to Inside Filtration Dead End or Cross flow mode

Typical Process Conditions

Air Scour Rate:	7.3 – 9.1 acfm (12.3 – 15.4 m ³ /h)
Air Scour Duration:	120 – 240 seconds
Air Scour Frequency:	Once every 20 – 60 minutes
Maintenance Clean Frequency:	1 – 3 times per day
Maintenance Clean Duration:	20 – 30 minutes
Disinfection Chemicals:	NaOCl, ClO ₂ or NH ₂ Cl
Cleaning Chemicals:	NaOCl, HCl, H ₂ SO ₄ , or Citric Acid

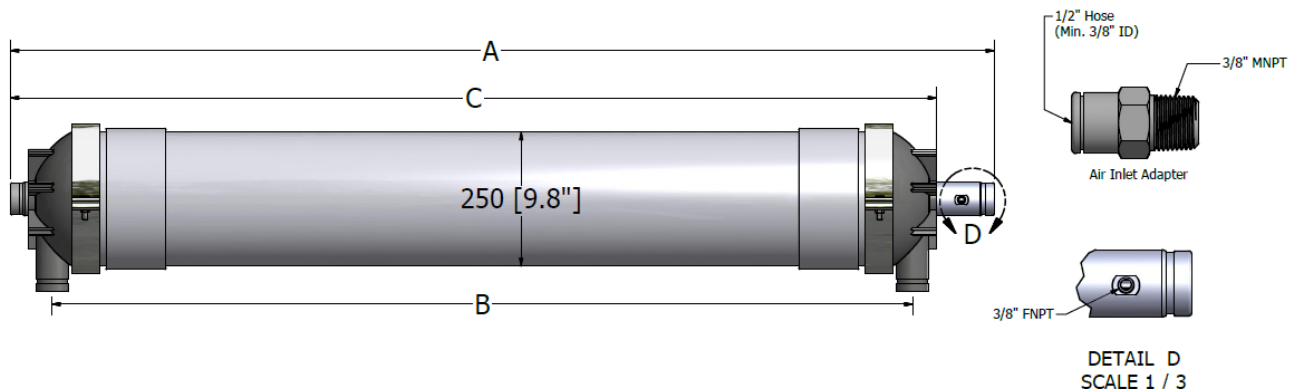

A, inches (mm)	B, inches (mm)	C, inches (mm)	Pipe connections	Dry Weight	Wet Weight
92.15 (2340.6)	83.11 (2110.9)	87.90 (2232.7)	2" Victaulic	135 lbs (62 kg)	260 lbs (118 kg)

[†] For 60 minutes or less.

[†] Typical module performance for most feedwaters.

[‡] The limitations shown here are for general use. The values may be more conservative for specific projects to ensure the best performance and longest life of the membrane.

Notice:

Hydranautics believes the information and data contained herein to be accurate and useful. The information and data are offered in good faith, but without guarantee, as conditions and methods of use of our products are beyond our control. Hydranautics assumes no liability for results obtained or damages incurred through the application of the presented information and data. It is the user's responsibility to determine the appropriateness of Hydranautics' products for the user's specific end uses.

10/23/12